

NASA Apollo Command Module News Reference

DATE	SITE		SPACECRAFT	RESULT
Dec. 8, 1964	White Sands	High Q abort test launch escape, earth landing systems and canard subsystems; Little Joe II was booster	BP 23	Successful
Sept. 18, 1964	Kennedy Space Center	Determined space vehicle launch exit environment on Saturn I	BP 15	Successful
May 28, 1964	Kennedy Space Center	Proved spacecraft compatibility with Saturn I launch vehicle; went into earth orbit	BP 13	Successful
May 13, 1964	White Sands	Transonic abort test utilizing Little Joe II to simulate a Saturn V launch vehicle; abort was performed at high speed with high loads	BP 12	Successful
Nov. 7, 1963	White Sands	Pad abort; tested the launch escape system's ability to perform an abort before launch while on the pad	BP 6	Successful

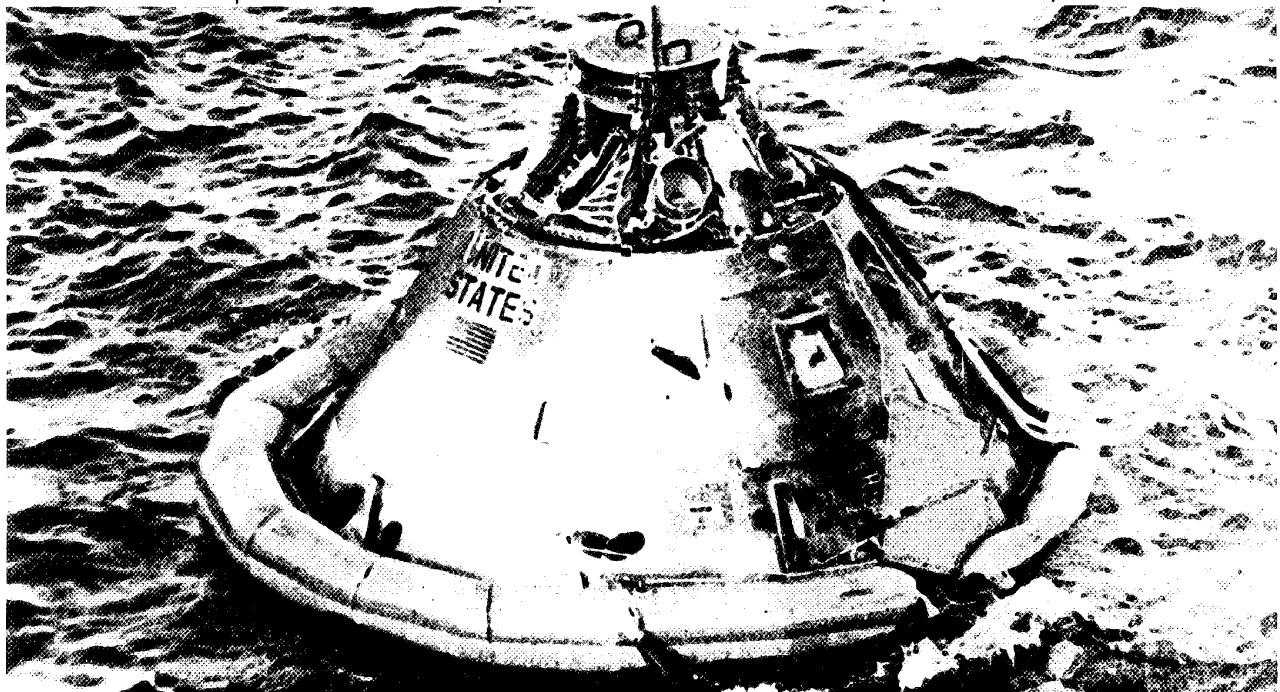

Recovery of first unmanned Apollo spacecraft by U.S.S. Boxer Feb. 26, 1966 in South Atlantic following launch by Saturn IB. During suborbital flight, spacecraft traveled 300 miles up.

P-45a

37

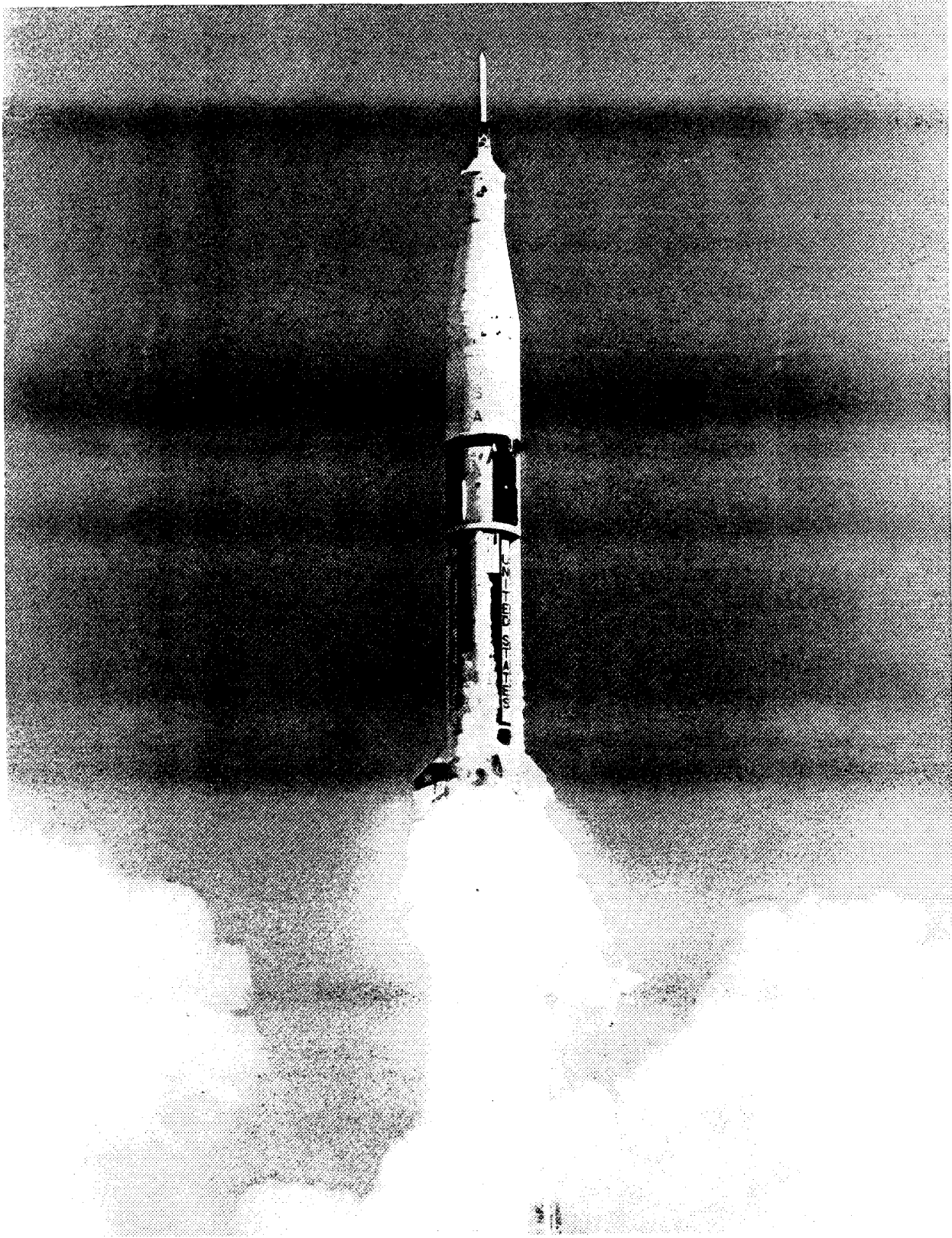

P-46

Saturn IB lifts CSM off pad on early Apollo flight test

COMMAND MODULE

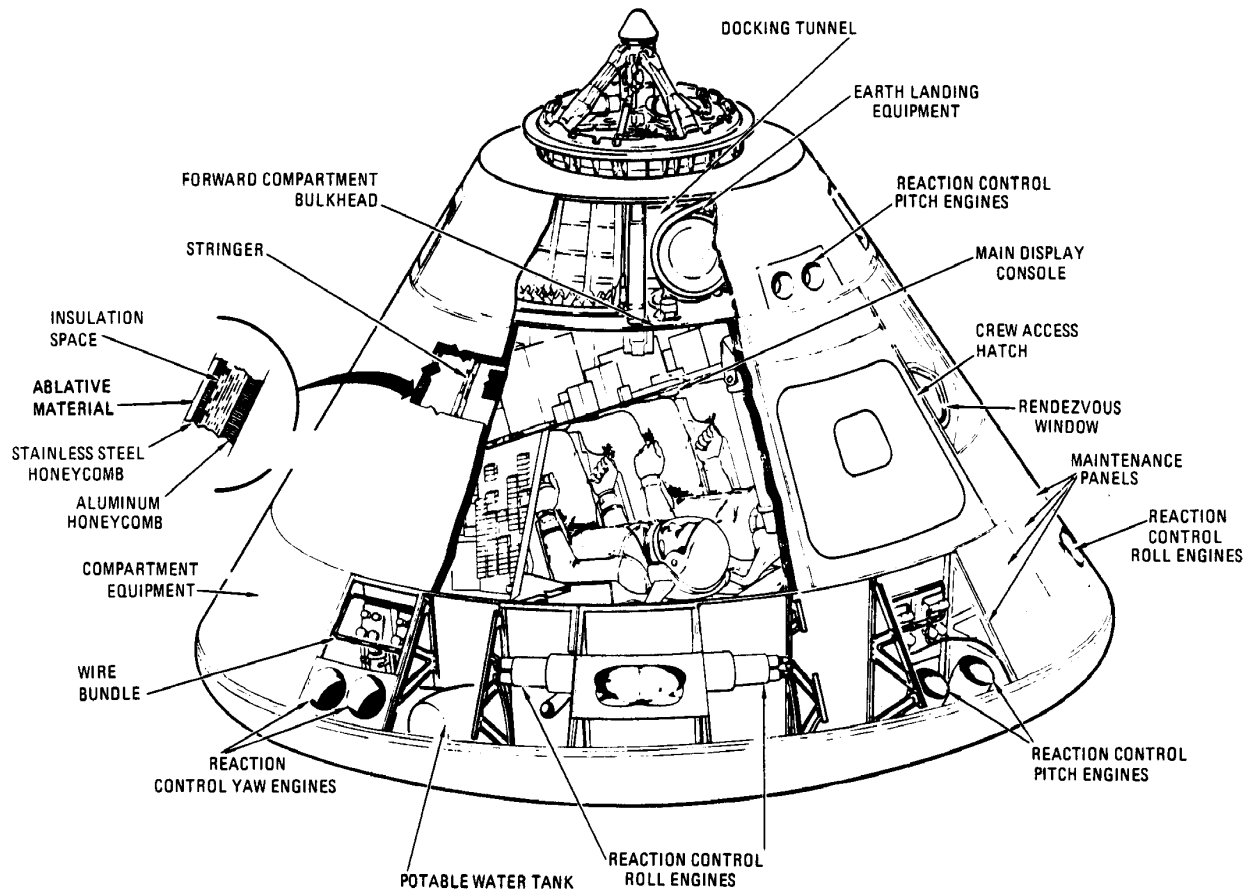

P-47

Dimensions

Height	10 ft 7 in.
Diameter	12 ft 10 in.
Weight (including crew)	13,000 lb
Weight (splashdown)	11,700 lb

Propellant

Reaction control subsystem (fuel—monomethylhydrazine; oxidizer—nitrogen tetroxide)	270 lb
--	--------

Function

The command module is the control center and living quarters for most of the lunar mission; one

man will spend the entire mission in it and the other two will leave it only during the lunar landing. It is the only part of the spacecraft recovered at the end of the mission.

Major Subsystems

- Communications
- Earth landing
- Electrical power
- Environmental control
- Guidance and navigation
- Launch escape
- Reaction control
- Service propulsion
- Stabilization and control
- Thermal protection (heat shields)

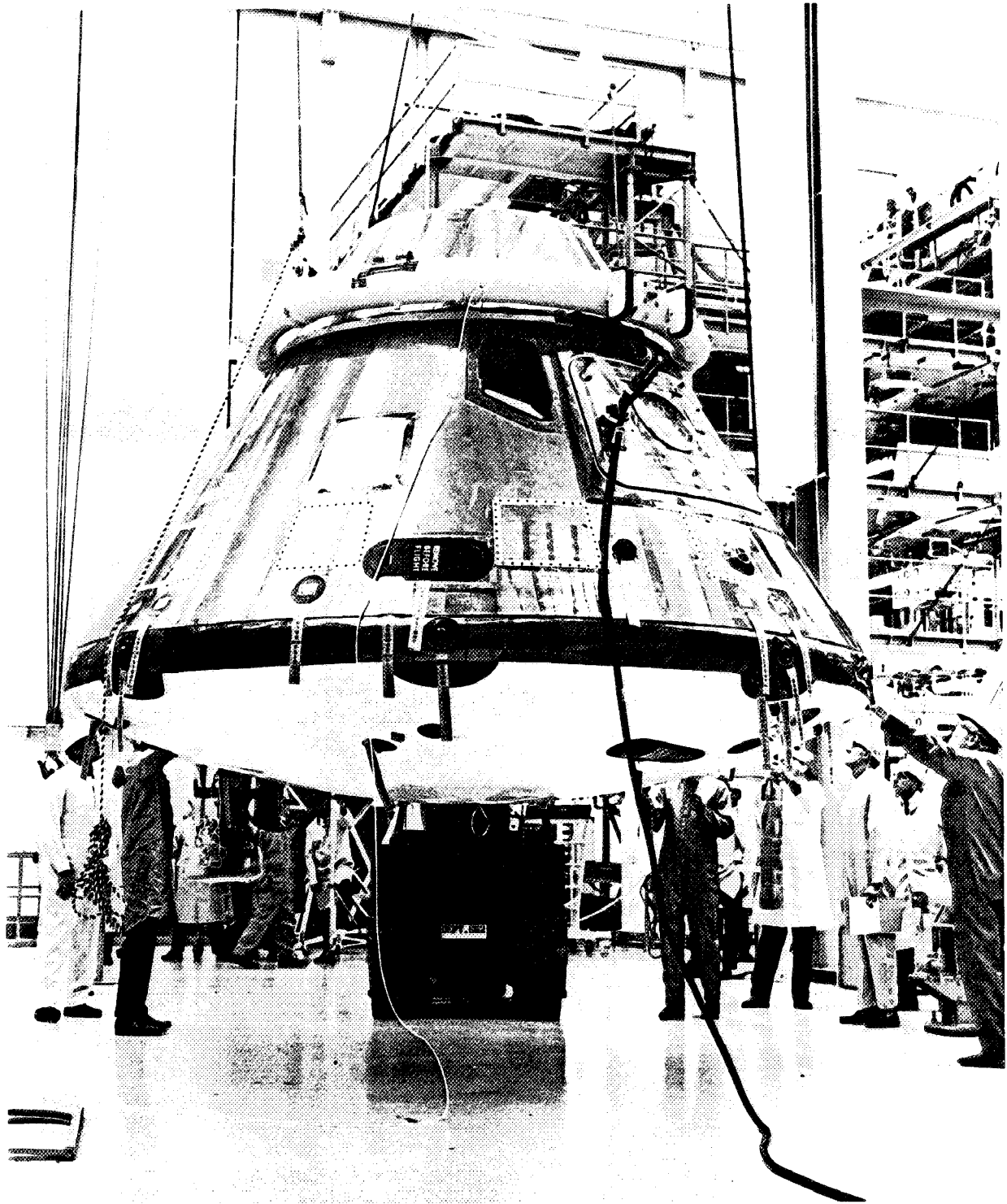

P-48

Command module, its checkout complete, is taken from test stand to be prepared for shipment to Florida

The CM is divided into three compartments: forward, crew, and aft. The forward compartment is the relatively small area at the apex of the module, the crew compartment occupies most of the center section of the structure, and the aft compartment is another relatively small area around the periphery of the module near the base.

During boost and entry the CM is oriented so that its aft section is down, like an automobile resting on its rear bumper. In this position the astronauts are on their backs; the couches are installed so that the astronauts face the apex of the module. In the weightlessness of space the orientation of the craft would make little difference except in maneuvers like docking, where the craft is moved forward so that the probe at the CM's apex engages the drogue on the LM. Generally, however, the module will be oriented in space so that its apex is forward.

Crewmen will spend much of their time on their couches, but they can leave them and move around. With the seat portion of the center couch folded, two astronauts can stand at the same time. The astronauts will sleep in two sleeping bags which are mounted beneath the left and right couches. The sleeping bags attach to the CM structure and have restraints so that a crewman can sleep either in or out of his space suit.

Food, water, clothing, waste management, and other equipment are packed into bays which line the walls of the craft. The cabin normally will be pressurized to about 5 pounds per square inch (about a third of sea level pressure) and the temperature will be controlled at about 75°F. The pressurization and controlled atmosphere will enable the three crewmen to spend much of their time out of their suits. They will be in their space suits, however, during critical phases of the mission such as launch, entry, docking, and crew transfer.

The astronaut in the left-hand couch is the spacecraft commander. In addition to the duties of command, he will normally operate the spacecraft's flight controls. The astronaut in the center couch is the CM pilot; his principal task is guidance and navigation, although he also will fly the spacecraft at times. On the lunar mission, he is the astronaut who will remain in the CM while the other two descend to the surface of the moon. The astronaut in the right-hand couch is the LM pilot and his principal task is management of spacecraft sub-systems.

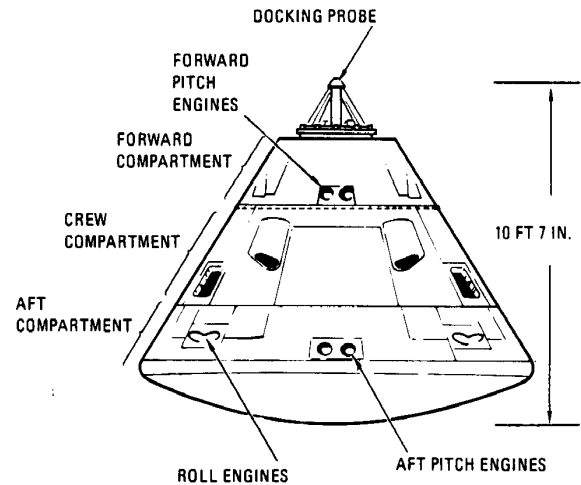
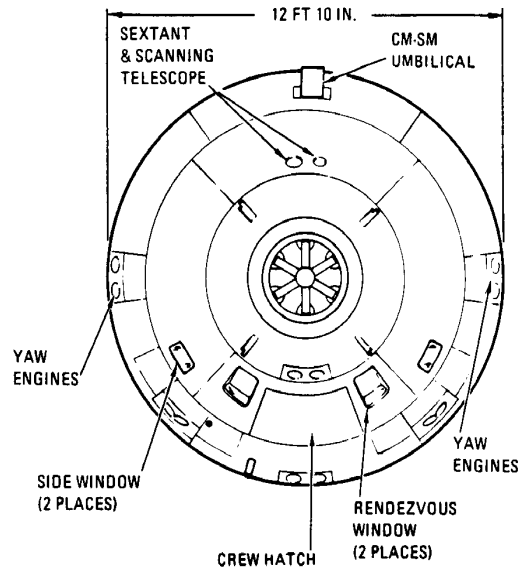

P-49

CM general arrangement

Although each has specific duties, any of the astronauts can take over the duties of another. The command module has been designed so that one astronaut can return it safely to earth.

STRUCTURE

The CM consists of two basic structures joined together: the inner structure (pressure shell) and the outer structure (heat shield).

The inner structure is of aluminum sandwich construction which consists of a welded aluminum inner skin, adhesively bonded aluminum honeycomb core and outer face sheet. The thickness of

the honeycomb varies from about 1-½ inches at the base to about ¼ inch at the forward access tunnel. This inner structure—basically the crew compartment—is the part of the module that is pressurized and contains an atmosphere.

The outer structure is the heat shield and is made of stainless steel brazed honeycomb brazed between steel alloy face sheets. It varies in thickness from ½ inch to 2-½ inches.

Part of the area between the inner and outer shells is filled with a layer of fibrous insulation as additional heat protection.

THERMAL PROTECTION (HEAT SHIELDS)

The interior of the command module must be protected from the extremes of environment that will be encountered during a mission. These include the heat of boost (up to 1200°F), the cold of space and the heat of the direct rays of the sun (about 280° below zero on the side facing away from the sun and 280° above zero on the other side), and—most critical—the intense temperatures of entry (about 5000°F).

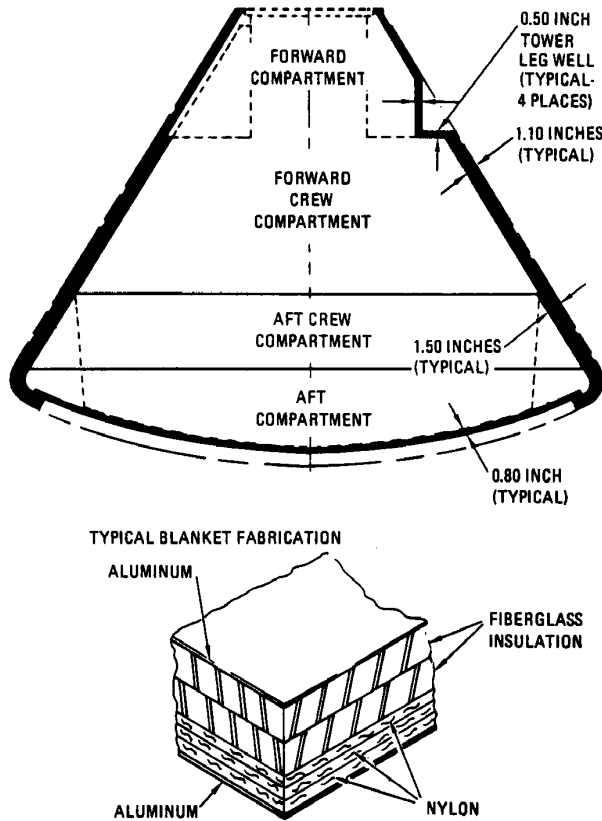

P-50

CM insulation

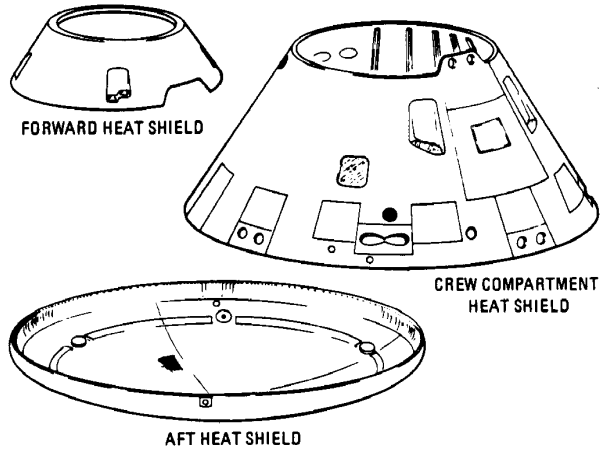

P-51

Heat shields

The heat of launch is absorbed principally through the boost protective cover, a fiberglass structure covered with cork which fits over the command module like a glove. The boost protective cover weighs about 700 pounds and varies in thickness from about 3/10 of an inch to about 7/8 of an inch (at the top). The cork is covered with a white reflective coating. The cover is permanently attached to the launch escape tower and is jettisoned with it at approximately 295,000 feet during a normal mission.

The insulation between the inner and outer shells, plus temperature control provided by the environmental control subsystem, protects the crew and sensitive equipment during the CM's long journey in space.

The principal task of the heat shield that forms the outer structure is to protect the crew from the fiery heat of entry—heat so intense that it melts most metals. The ablative material that does this job is a phenolic epoxy resin, a type of reinforced plastic.

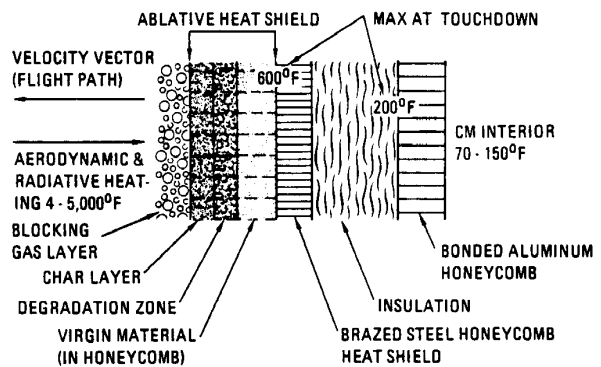

P-52

Mechanics of ablative material



P-53

Special ablative material is injected into each cell of heat shield by technicians at Avco plant in Lowell, Mass.

This material turns white hot, chars, and then melts away, but it does it in such a way that the heat is rejected by the shield and does not penetrate to the surface of the spacecraft.

The ablative material controls the rate of heat absorption by charring or melting rapidly. This dissipates the heat and keeps it from reaching the inner structure.

The command module enters the atmosphere with its base down; this is covered by the aft heat shield which is the thickest portion.

The heat shield varies in thickness: the aft portion is 2 inches and the crew compartment and forward

portions are ½ inch. Total weight of the shield is about 3,000 pounds. The heat shield has several outer coverings: a pore seal, a moisture barrier (a white reflective coating), and a silver Mylar thermal coating that looks like aluminum foil.

The heat shield panels are produced by Aeronca Manufacturing Co., Middletown, Ohio, and the ablative coating was developed and applied by Avco Corp., Lowell, Mass.

IMPACT ATTENUATION

During a water impact the CM deceleration force will vary from 12 to 40 G's, depending on the shape

of the waves and the CM's rate of descent. A major portion of the energy (75 to 90 percent) is absorbed by the water and by deformation of the CM structure. The module's impact attenuation system reduces the forces acting on the crew to a tolerable level.

The impact attenuation system is part internal and part external. The external part consists of four crushable ribs (each about 4 inches thick and a foot in length) installed in the aft compartment. The ribs are made of bonded laminations of corrugated aluminum which absorb energy by collapsing upon themselves at impact. The main parachutes suspend the CM at such an angle that the ribs are the first point of the module that hits the water.

The internal portion of the system consists of eight struts which connect the crew couches to the CM structure. These struts (two each for the Y and Z axes and four for the X axis) absorb energy by deforming steel wire rings between an inner and an outer piston. The struts vary in length from 34 to 39 inches and have a diameter of about 2½ inches.

The axes of the spacecraft are three straight lines, each at a right angle to the other two. They are used for reference and to describe the spacecraft's movements. The X axis is the line running from the apex of the command module through its base; the Y axis is the line running laterally, or from side to side through the couches; the Z axis is the line running up and down, or from the head to the feet of the astronauts in their couches. The command module's

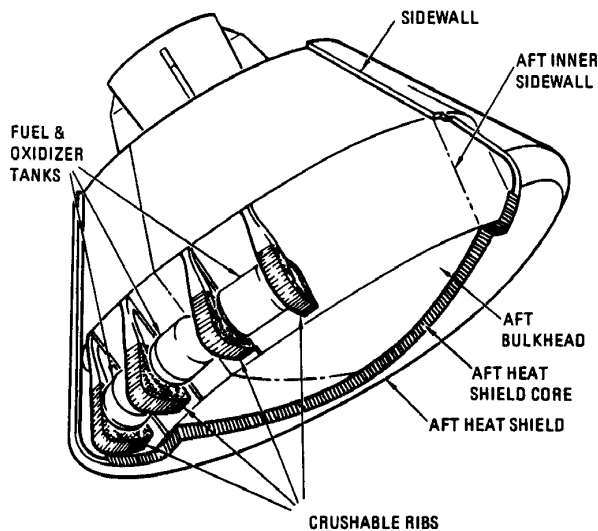

P-54

External attenuation system

movement about the X axis is called roll, about the Y axis is called pitch, and about the Z axis is called yaw.

FORWARD COMPARTMENT

The forward compartment is the area around the forward (docking) tunnel. It is separated from the crew compartment by a bulkhead and covered by the forward heat shield. The compartment is divided into four 90-degree segments which contain earth landing equipment (all the parachutes, recovery antennas and beacon light, and sea recovery sling), two reaction control engines, and the forward heat shield release mechanism.

The forward heat shield contains four recessed fittings into which the legs of the launch escape tower are attached. The tower legs are connected to the CM structure by frangible (brittle) nuts which contain small explosive charges. When the launch escape subsystem is jettisoned, these charges are fired, breaking the nuts and separating the tower from the module.

At about 25,000 feet during entry, the forward heat shield is jettisoned to expose the earth landing equipment and permit deployment of the parachutes.

AFT COMPARTMENT

The aft compartment is located around the periphery of the command module at its widest part, just forward of (above) the aft heat shield. The compartment is divided into 24 bays by the 24 frames of the structure. In these bays are 10 reaction control engines; the fuel, oxidizer, and helium tanks for the CM reaction control subsystem; water tanks; the crushable ribs of the impact attenuation system; and a number of instruments. The CM-SM umbilical—the point where wiring and plumbing runs from one module to the other—also is in the aft compartment. The panels of the heat shield around the aft compartment are removable for maintenance of the equipment before flight.

CREW COMPARTMENT

The crew compartment is a sealed cabin with a habitable volume of 210 cubic feet. Pressurization and temperature are maintained by the environmental control subsystem. In it are the controls and

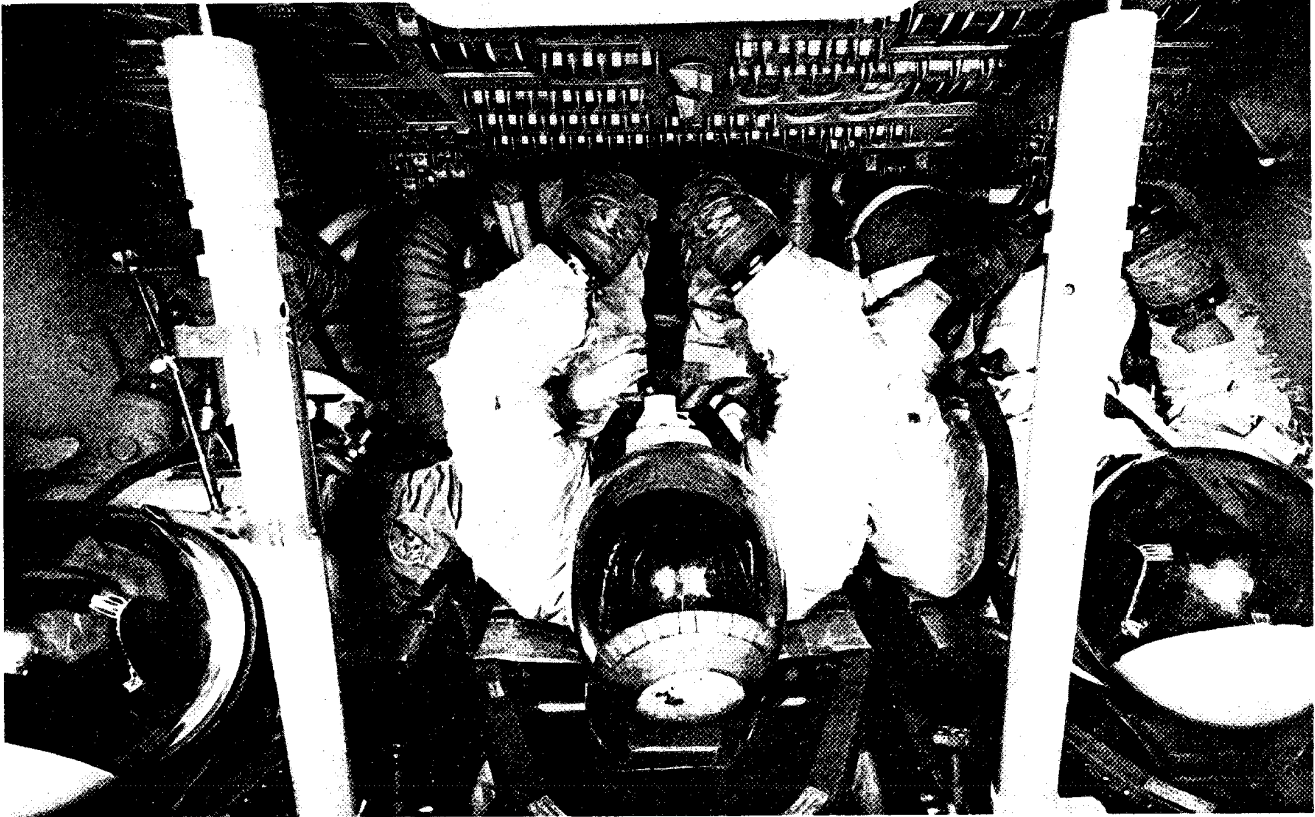

P-55

Astronauts check out crew compartment, train in use of controls

displays for operation of the spacecraft, crew couches, and all the other equipment needed by the crew. It contains two hatches, five windows, and a number of bays or cupboards packed with equipment.

HATCHES

The two CM hatches are the side hatch, used for getting in and out of the module, and the forward hatch, used to transfer to and from the lunar module when the two modules are docked.

The side hatch is a single integrated assembly which opens outward and has primary and secondary thermal seals. It is about 29 inches high and 34 inches wide. The hatch normally contains a small (about 9 inches in diameter) window, but has provisions for installation of an airlock. The hatch weighs about 225 pounds; with the airlock it

weighs about 245 pounds.

The hatch normally is operated by a handle which the crewman pumps back and forth. The handle drives a ratchet mechanism which opens or closes the 12 latches around the periphery of the hatch. The latches are so designed that pressure exerted against the hatch serves only to increase the locking pressure of the latches. If the latch gear mechanism should fail, it can be disconnected and the latches opened or closed manually.

The hatch also can be opened from the outside by a tool that is part of the crew's tool set and is carried by ground personnel. The tool is the emergency wrench, essentially a modified allenhead L-wrench. It is 6-1/4 inches long and has a 4-1/4-inch drive shaft.

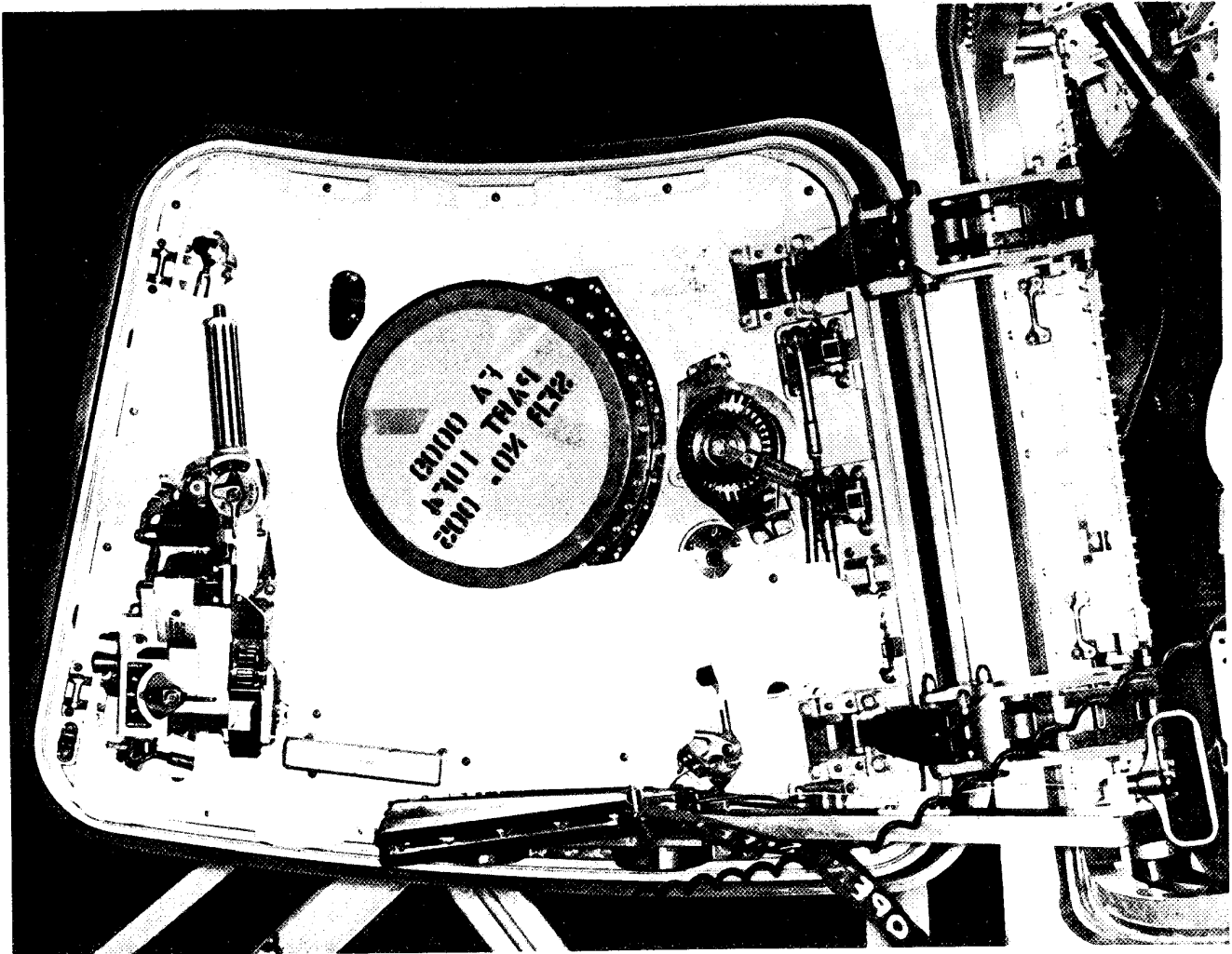

Side (unified) hatch with hard plastic cover that protects components during ground handling; cover is removed before flight

P-56

The hatch handle mechanism also operates the mechanism which opens the access hatch in the boost protective cover. A counterbalance assembly enables the hatch and boost protective cover hatch to be opened easily. This consists of two nitrogen bottles and a piston assembly. Each nitrogen bottle contains about 5-1/2 cubic inches of gas under a pressure of 5,000 pounds per square inch. One of the bottles is punctured on the launch pad, permitting the gas to stroke the piston and force the door open when the latches are released. A pressure of about 2,200 pounds per square inch is needed to open the door.

The ground crew can easily close the hatch by pushing it. In the weightlessness of space, the crew

NOTE: HINGES NOT SHOWN

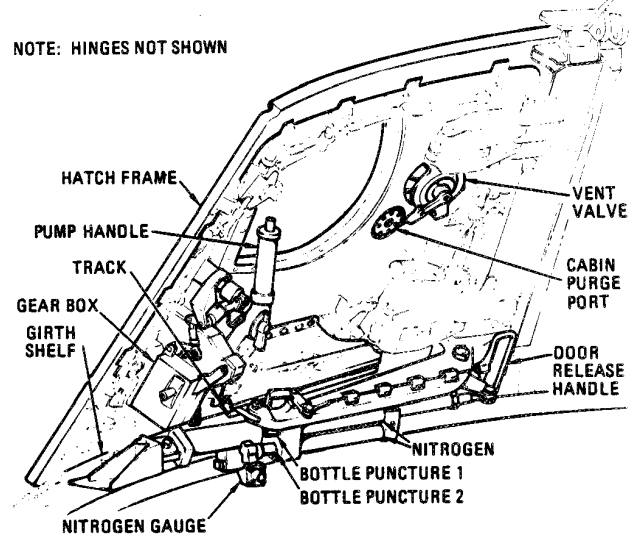

P-57

Major components of unified hatch

can close the hatch from the inside by pulling on a handle near the lower hinge which swings the hatch inward. Another handle near the opposite edge of the door is provided primarily for the use of astronauts engaged in extravehicular activity.

The piston cylinder and nitrogen bottle can be vented after launch since the counter-balance assembly is not needed in space. If it is vented, the second nitrogen bottle can be used to open the hatch after landing. A knob on this bottle is used to puncture it and release the gas into the system.

In case some deformation or other malfunction prevented the latches from engaging, three jackscrews are provided in the crew's tool set to hold the door closed. The jackscrews engage three catches on the hatch and parallel catches on the inner structure. The jackscrews are then tightened, pulling the hatch closed tight enough to withstand the thermal load of entry.

The side hatch also contains a valve to vent the cabin pressure. The valve handle normally is locked in the down position. The crewman simply releases the lock, pulls the handle up and winds it in a clockwise direction, opening the valve. The valve will vent the cabin pressure in one minute. The valve also can be operated from the outside by using the same tool used to open the door.

The forward (docking) hatch is a combined pressure and ablative hatch mounted at the top of the docking tunnel. It is about 30 inches in diameter and weighs about 80 pounds. The exterior or upper side of the hatch is covered with a half-inch of insulation and a layer of aluminum foil.

The forward hatch has a six-point latching arrangement operated by a pump handle similar to that on the side hatch except that only one stroke is needed to open the latches. The handle is offset so that it can be reached easily by a crewman standing in the tunnel. This hatch also can be opened from the outside. It has a pressure equalization valve so that the pressure in the tunnel and that in the LM can be equalized before the hatch is removed. The valve is similar to the vent valve in the side hatch. There are also provisions for opening the latches manually if the handle gear mechanism should fail.

WINDOWS

The CM has five windows: two side, two rendezvous, and a hatch window. On some missions the

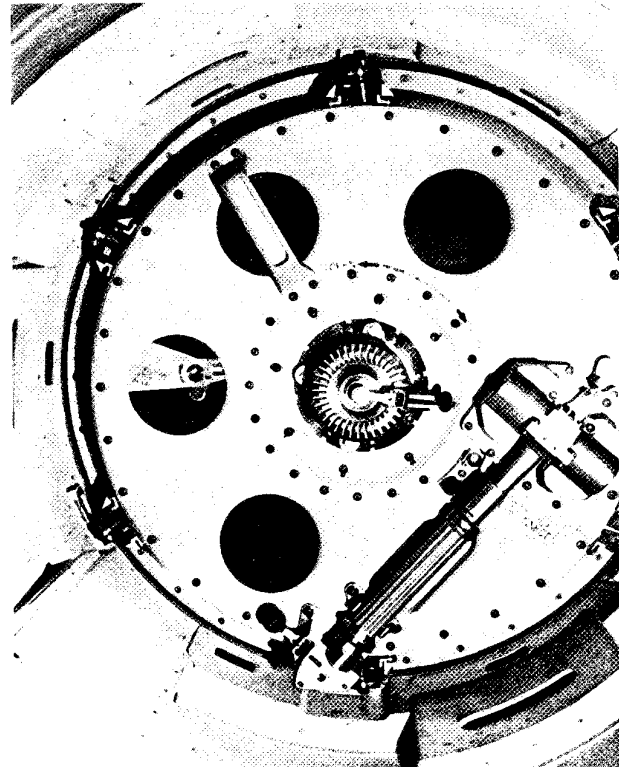

P-57a *Forward (tunnel) hatch from inside CM*



P-58 *Foil covers exterior of forward hatch*

hatch window may be replaced by a scientific airlock. The side windows, about 13 inches square, are positioned at the side of the left and right couches and are used for observation and photography. The triangular rendezvous windows, about 8 by 13 inches, face the left and right couches and permit a view forward (toward the apex of the module). They are used to aid in the rendezvous and

docking maneuvers as well as for observation. The hatch window is over the center couch.

The windows each consist of inner and outer panes. The inner windows are made of tempered silica glass with 1/4-inch thick double panes, separated by a tenth of an inch. The outer windows are made of amorphous-fused silicon with a single pane seven-tenths of an inch thick. Each pane has an anti-reflecting coating on the external surface and a blue-reflective coating on the inner surface to filter out most infrared and all ultraviolet rays. The outer window glass has a softening temperature of 2800°F and a melting point of 3110°F. The inner window glass has a softening temperature of 2000°F.

Each window has a shade which can be installed to cut off all outside light. The shades are made of aluminum sheet, have a non-reflective inner surface, and are held in place by wing levers.

EQUIPMENT BAYS

The interior of the command module is lined with equipment bays or cupboards which contain all of the items needed by the crew for up to 14 days, as well as much of the electronics and other equipment needed for operation of the spacecraft. The bays are named according to their position with reference to the couches. The left-hand and right-hand bays are beside the left and right couches, respectively; the left-hand forward and right-hand forward bays are to the side and in front of the left and right couches, respectively; the lower bay is at the foot of the center couch; and the aft bay is on the aft bulkhead beneath the couches.

The lower equipment bay is the largest and contains much critical equipment. It is the navigation station and contains most of the guidance and navigation electronics, as well as the sextant and telescope, the computer, and a computer keyboard. Most of the telecommunications subsystem electronics are in this bay, as well as the five batteries, inverters, and battery charger of the electrical power subsystem. Stowage areas in the bay contain food supplies, scientific instruments, and other astronaut equipment.

The left-hand equipment bay contains key elements of the environmental control subsystem, including the environmental control unit, the oxygen surge tank, and displays and controls. Space is provided on this bay for stowing the forward hatch when the command and lunar modules are docked and the tunnel between the craft is open.

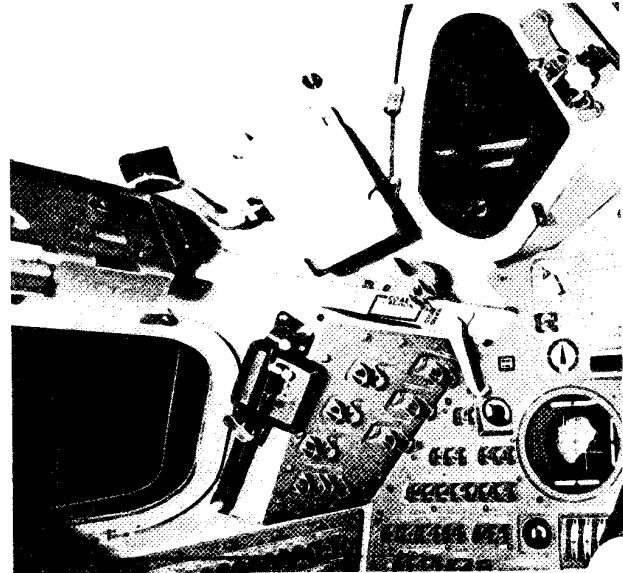

P-59

Side (left) and rendezvous windows

The left-hand forward equipment bay also contains environmental control subsystem equipment, as well as the water delivery unit and clothing storage.

The right-hand equipment bay contains waste management system controls and equipment, electrical power equipment, and a variety of electronics, including sequence controllers and signal conditioners. Food also is stored in a compartment in this bay.

The right-hand forward equipment bay is used principally for stowage and contains such items as survival kits, medical supplies, optical equipment, the LM docking target, and bio-instrumentation harness equipment.

The aft equipment bay is used for storing space suits and helmets, life vests, the fecal canister, portable life support systems (backpacks), and other equipment, and includes space for stowing the probe and drogue assembly.

PROTECTION PANELS

Protection panels are mounted throughout the interior of the command module as additional protection for spacecraft equipment. The panels are made of aluminum in varying thicknesses and are used to cover wiring and equipment and to smooth out irregular surfaces of the cabin. The panels prevent loose equipment or debris from getting into crevices of the spacecraft during preparation for

flight. They also help suppress fire by sealing off areas and protect critical parts from damage during work by ground personnel.

MIRRORS

Internal and external mirrors are provided to aid astronauts' visibility. The internal mirrors (4 by 6 inches) include one for each couch and are designed to help the astronaut see to adjust his restraint harness and locate his couch controls while in his pressurized suit. The external mirrors are 2-1/2 by 3-1/2 inches and are located at the top and bottom of the right-hand rendezvous window so that the astronaut in the right-hand couch can verify parachute deployment during entry.

CM-SM CONNECTION

For most of an Apollo mission, the command and service modules are attached; they separate only a short time before the command module enters the atmosphere.

The two modules are connected by three tension ties which extend from the CM's aft heat shield to six compression pads on the top of the SM. The tension ties are essentially stainless steel straps about 2-1/2 inches wide and 4 inches long bolted at one end to the CM and at the other to the SM. The CM rests base down on the six compression pads, which are circular metal "cups," three of them about 4 inches in diameter and three about 6 inches in diameter. The areas in the heat shield which rest on the pads are reinforced with laminated fiberglass.

The two modules also are connected through the CM-SM umbilical, an enclosure protruding from the CM on the side opposite the side hatch. The umbilical is the wiring and tubing through which vital power, water, oxygen, and water-glycol flows from one module to the other. These connections are covered by an aluminum fairing about 18 inches wide and 40 inches long.

At separation, electrical circuits are deadfaced (power cut off) and valves closed at the umbilical,

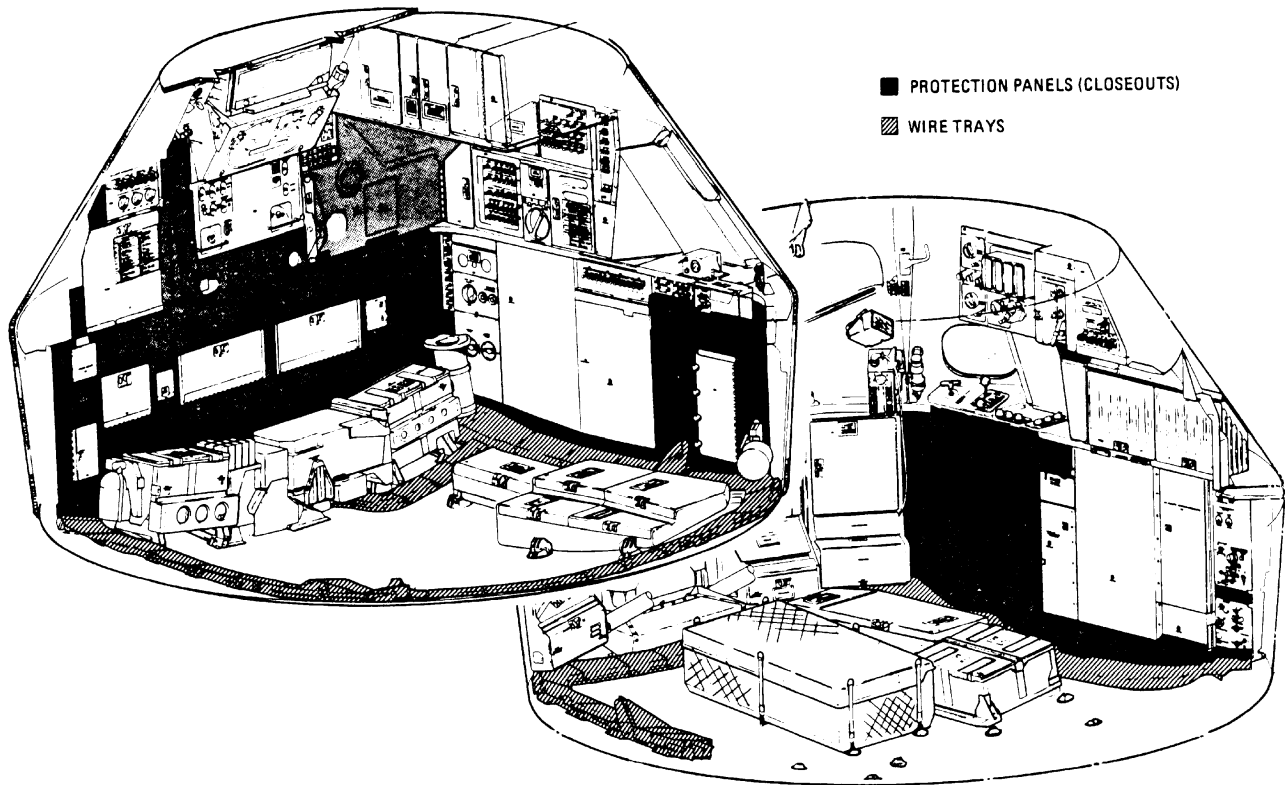

P-60

Protection panels and wire trays

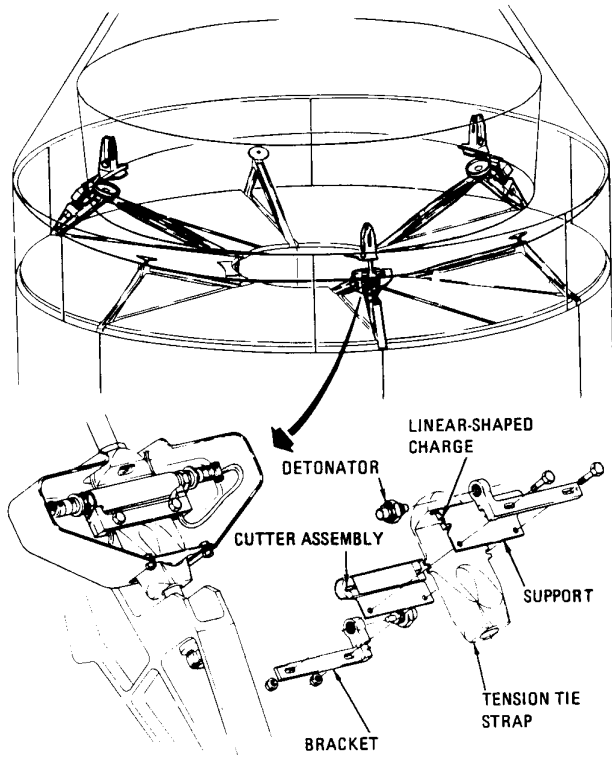

P-61

CM-SM separation system

a guillotine mechanism cuts the connecting wires and tubing, and small charges sever the tension ties. The umbilical firing pulls away from the CM and remains attached to the SM. The guillotine that severs the wires and tubes consists of two

stainless steel blades, either one of which will cut all the connections. The guillotine is driven by redundant detonating cord charges. The tension ties are severed by linear-shaped charges set off by detonators. The signals that set off the detonators, the detonators themselves, and the charges are all redundant.

The area between the bottom (aft) of the CM and the top of the SM where the two modules are joined is enclosed by a fairing 26 inches high. This fairing is part of the service module and contains space radiators for the electrical power subsystem.

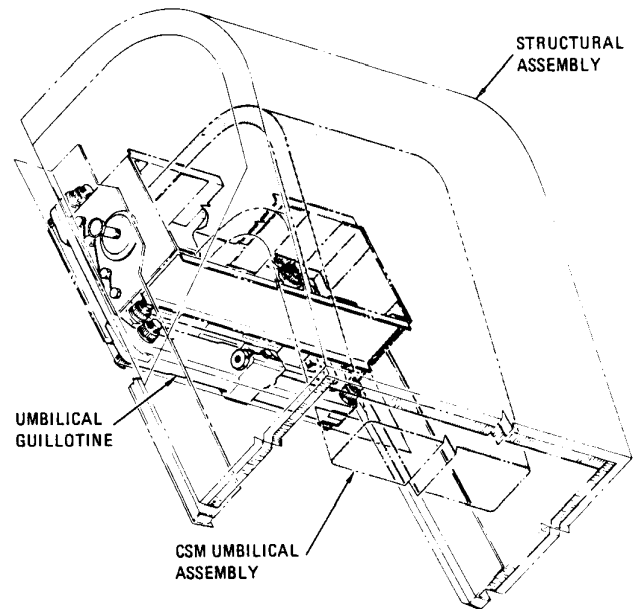

P-62

Umbilical separation system

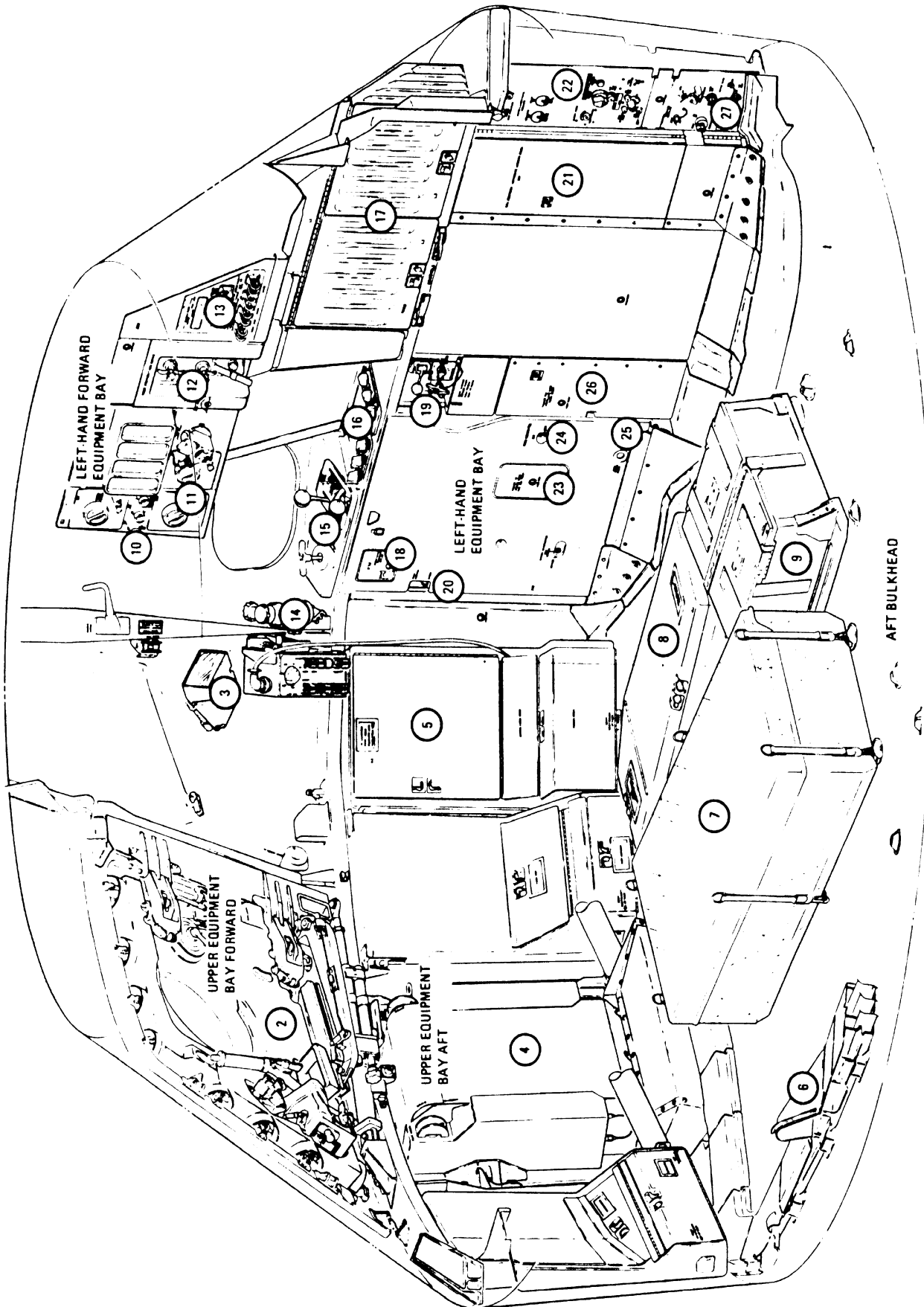

AFT BULKHEAD, UPPER, & LEFT-HAND EQUIPMENT BAYS

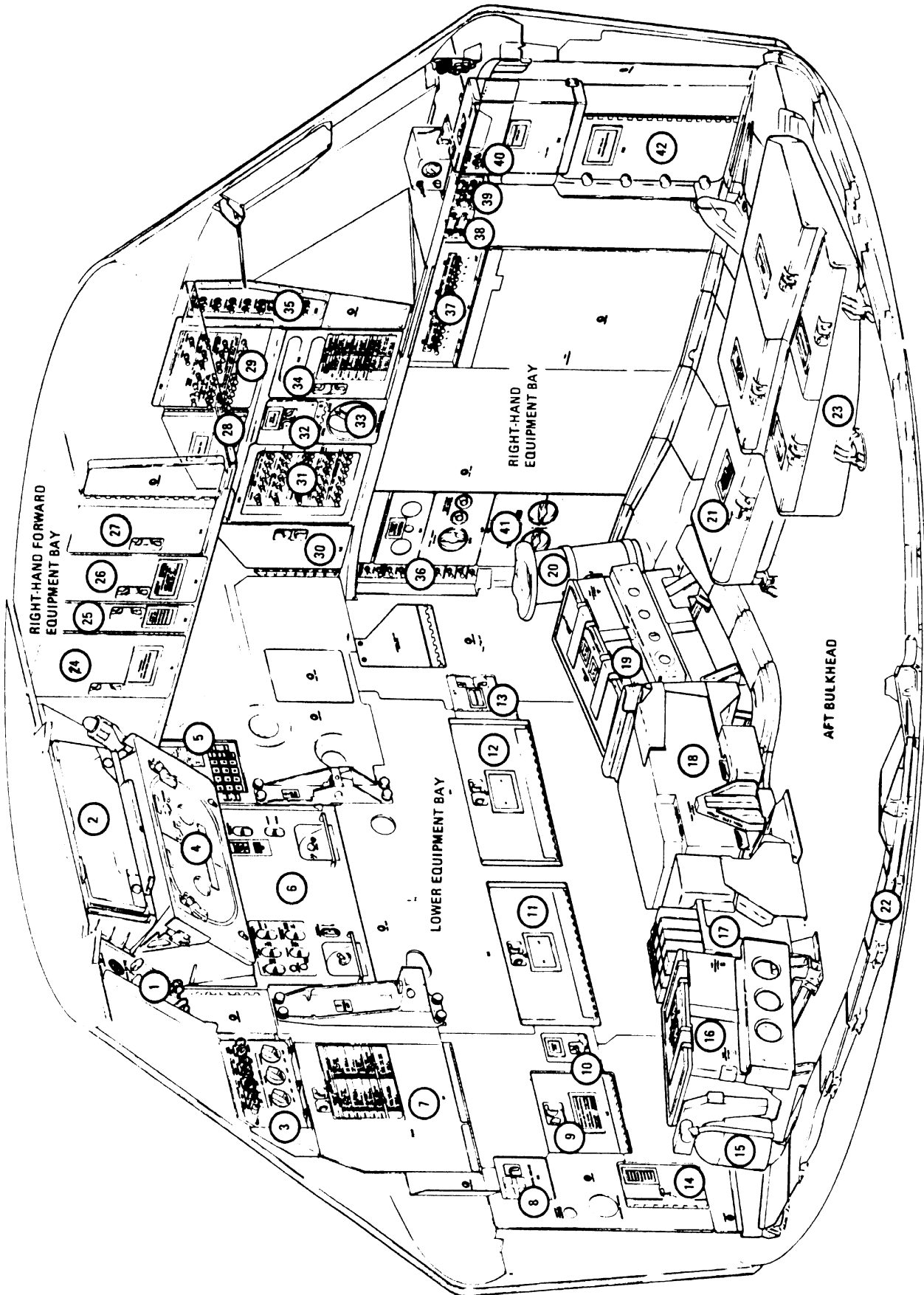

AFT BULKHEAD, LOWER, AND RIGHT-HAND EQUIPMENT BAYS

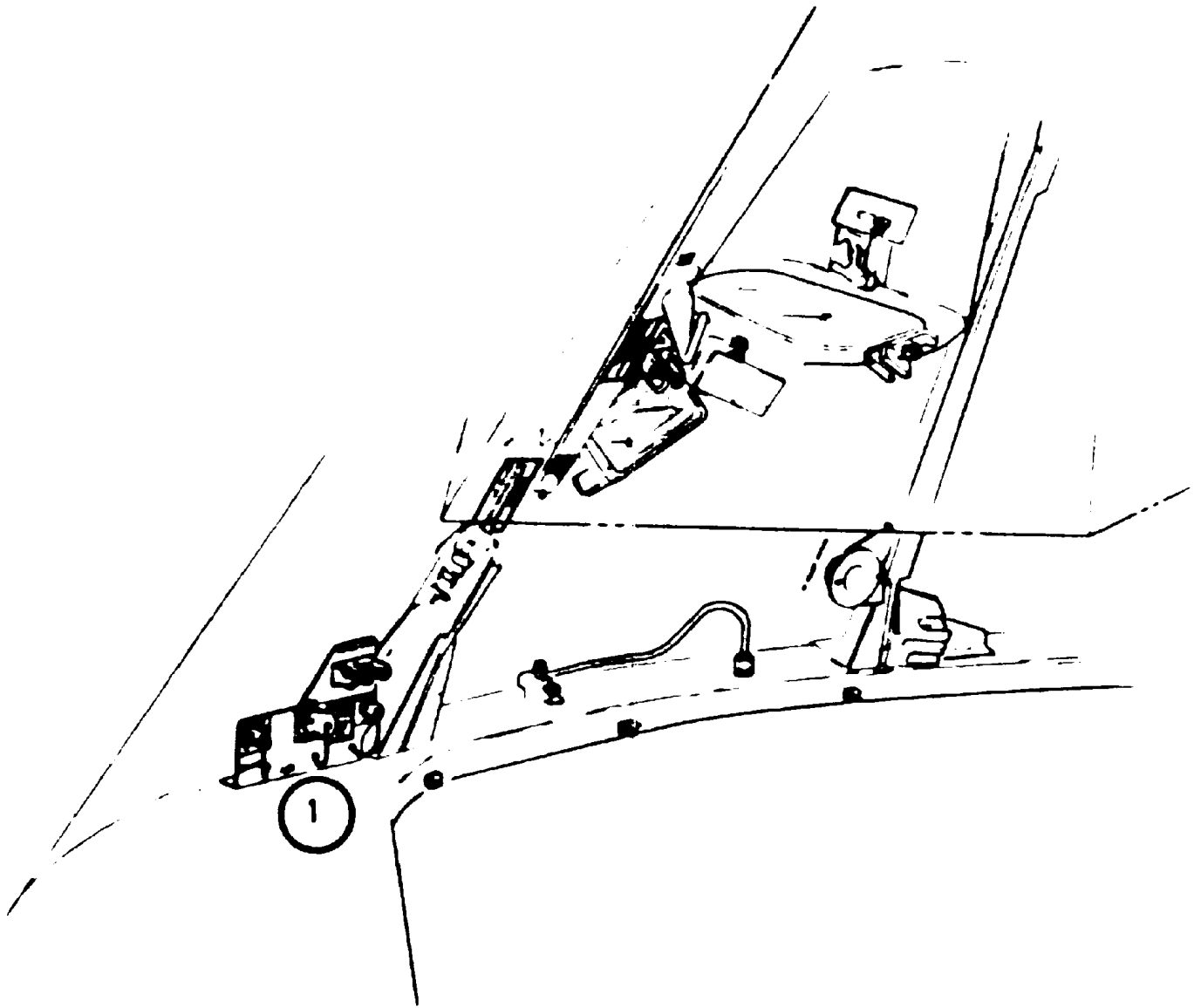

NASA Apollo Command Module News Reference

P-63 *Arrangement of equipment in interior of command module*

LOWER EQUIPMENT BAY

- ① AUXILIARY TEST PANEL (101)
- ② OPTICS STOWAGE COMPARTMENT
- ③ LIGHTING CONTROL PANEL (100)
- ④ OPTICS PANEL (121)
- ⑤ DISPLAY KEYBOARD (140)
- ⑥ GUIDANCE & NAVIGATION PANEL (122)
- ⑦ STOWAGE COMPARTMENT (FOOD)
- ⑧ STOWAGE COMPARTMENT (MEDICAL KIT)
- ⑨ STOWAGE COMPARTMENT (CAMERA EQUIPMENT)
- ⑩ STOWAGE COMPARTMENT (CO₂ ABSORBERS)
- ⑪ STOWAGE COMPARTMENT (CO₂ ABSORBERS)
- ⑫ STOWAGE COMPARTMENT (CO₂ ABSORBERS)
- ⑬ STOWAGE COMPARTMENT
- ⑭ STOWAGE COMPARTMENT (CAMERA EQUIPMENT)

AFT BULKHEAD

- ⑮ FIRE EXTINGUISHERS
- ⑯ STOWAGE LOCKER
- ⑰ PANEL (375)
- ⑱ FLIGHT QUALIFICATION TAPE RECORDER
- ⑲ STOWAGE LOCKER
- ⑳ FECAL CANISTER
- ㉑ STOWAGE LOCKER
- ㉒ ELECTRICAL CABLEWAY
- ㉓ STOWAGE LOCKER

LEFT-HAND FORWARD EQUIPMENT BAY

- ⑩ COMMUNICATION CABLE CONNECTORS
- ⑪ OXYGEN HOSE CONNECTORS
- ⑫ FOOD PREPARATION WATER UNIT
- ⑬ TIMER PANEL (306)

UPPER EQUIPMENT BAY AFT

- ④ EMERGENCY OXYGEN & REPRESSURIZATION SYSTEM
- ⑤ STOWAGE LOCKER

AFT BULKHEAD

- ⑥ ELECTRICAL CABLEWAY
- ⑦ SUIT STOWAGE BAGS
- ⑧ STOWAGE LOCKER
- ⑨ STOWAGE LOCKER

RIGHT-HAND FORWARD EQUIPMENT BAY

- ⑳ STOWAGE COMPARTMENT
- ㉑ STOWAGE COMPARTMENT
- ㉒ STOWAGE COMPARTMENT
- ㉓ STOWAGE COMPARTMENT

RIGHT-HAND EQUIPMENT BAY

- ㉔ STOWAGE COMPARTMENT
- ㉕ AUXILIARY CIRCUIT BREAKER PANEL A (225)
- ㉖ STOWAGE COMPARTMENT
- ㉗ AUXILIARY CIRCUIT BREAKER PANEL B (226)
- ㉘ STOWAGE COMPARTMENT
- ㉙ STOWAGE COMPARTMENT
- ㉚ STOWAGE COMPARTMENT
- ㉛ STOWAGE COMPARTMENT
- ㉜ CIRCUIT BREAKER PANEL (229)

- ㉝ BATTERY CIRCUIT BREAKER PANEL (250)
- ㉞ POWER CIRCUIT BREAKER PANEL (275)
- ㉟ CIRCUIT BREAKER PANEL (276)
- ㊱ CIRCUIT BREAKER PANEL (277)
- ㊲ UPRIGHTING SYSTEM PANEL (278)
- ㊳ WASTE MANAGEMENT SYSTEM PANELS
- ㊴ STOWAGE COMPARTMENT

LEFT-HAND EQUIPMENT BAY

- ⑭ OPTICAL ALIGNMENT SIGHT
- ⑮ CABIN PRESSURE RELIEF CONTROL PANEL (325)
- ⑯ OXYGEN & GLYCOL CONTROL PANEL (326)
- ⑰ STOWAGE COMPARTMENT
- ⑱ OXYGEN SURGE TANK PRESSURE RELIEF
- ⑲ OXYGEN DEMAND REGULATOR VALVE PANEL (380)
- ㉑ PLUC CONTROL PANEL (376)
- ㉒ ENVIRONMENTAL CONTROL FILTER ACCESS PANEL (350)
- ㉓ OXYGEN CONTROL PANEL (351)
- ㉔ SEAWATER PLUG ACCESS PANEL
- ㉕ WATER-GLYCOL ACCUMULATOR FILL CONTROL PANEL (379)
- ㉖ WATER-GLYCOL ACCUMULATOR ISOLATION CONTROL PANEL (378)
- ㉗ COOLANT CONTROL PANEL (382)
- ㉘ WATER CONTROL PANEL (352)

PAGE NOT COPIED

PAGE IS BLANK

PAGE # 52

SERVICE MODULE

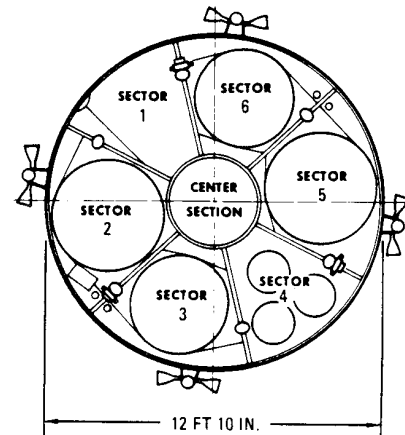
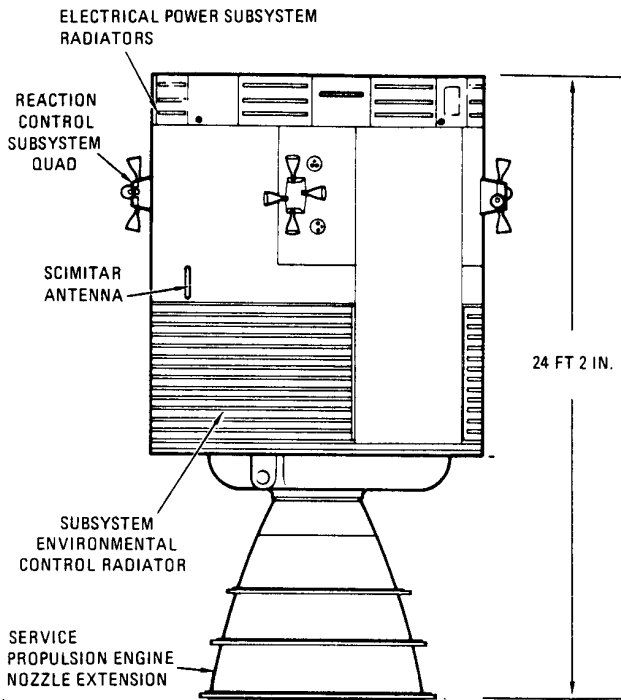

- SECTOR 2 } SERVICE PROPULSION AND SYSTEM
- SECTOR 3 } OXIDIZER TANKS
- SECTOR 4 } OXYGEN TANKS, HYDROGEN TANKS, FUEL CELLS
- SECTOR 5 } SERVICE PROPULSION SUBSYSTEM
- SECTOR 6 } FUEL TANKS
- CENTER SECTION - SERVICE PROPULSION ENGINE AND HELIUM TANKS

P-64

Dimensions

Height	24 ft. 2 in.
Diameter	12 ft. 10 in.
Weight (loaded)	55,000 lb.
Weight (dry)	11,500 lb.

Propellant

SPS fuel	15,766 lb.
SPS oxidizer	25,208 lb.
RCS	1,362 lb.

Function

The service module contains the main spacecraft propulsion system and supplies most of the spacecraft's consumables (oxygen, water, propellant, hydrogen). It is not manned. The service module remains attached to the command module until just before entry, when it is jettisoned and is destroyed during entry.

Major Subsystems

- Electrical power
- Environmental control
- Reaction control
- Service propulsion
- Telecommunications